



The WHOLE Solution

InnoGain SPB-DG

Description:

InnoGain SPB-DG creates vertical smooth though holes or openings in concrete elements which are ideal for cables, electric, sewer or water supply.

The InnoGain SPB-DG can be attached to the formwork within one minute. The fixing is done with a trapezoidal 16mm screw thread in the screw base or magnetic base and does not require any further support.

The SPB-DG limits various labor-intensive activities such as (dangerously) cutting PVC or plastic pipes, keeping them in place during the pour, but also taping them against concrete water.

After the InnoGain has been manually removed, a clean, dry and smooth hole remains.

By not using traditional steel or plastic pipes, raw materials are limited and CO2 emissions for this application are kept to a minimum.

System:

The InnoGain SPB-DG is based on a unique interplay between a rigid inner core and the flexible profiled outer cover.

The flexible outer cover of the SPB-DG will undergo a diameter reduction during manual removal. After removal, the flexible outer part returns to its original shape.

The special composition of the rubber of the InnoGain SPB-D prevents the adhesion of concrete residues. This allows them to be used again immediately.



Benefits:

- Significant material and labor saving.
- Reusable with minimal maintenance.
- Durable by saving steel- or plastic pipes.
- Saving logistics and transport costs.
- Guaranteed angle mounting.
- Good sealing against concrete water.
- Easy in use.
- Mounted within 1 minute.
- No specialist tools required.
- 100% recyclable.



Ballykillduff, Tobinstown, Tullow, Co. Carlow.

www.InnoGain.com

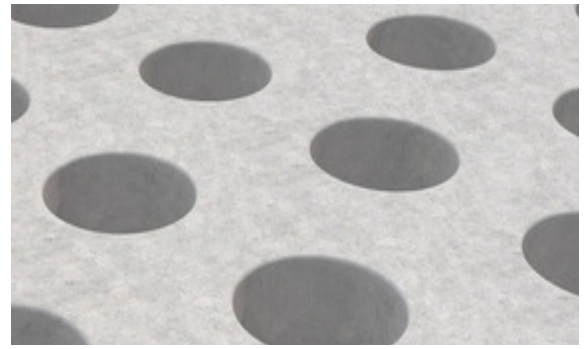

InnoGain SPB-DG

Specification:

InnoGain SPB-DG

Article	Description	Size (mm)	Weight (KG)
I244300	SPB-DG	Ø40x300/330	
I245300	SPB-DG	Ø50x300/330	
I246200	SPB-DG	Ø60x200/250	1.23
I246300	SPB-DG	Ø60x300/330	1.62
I247300	SPB-DG	Ø70x300/330	1.92
I249300	SPB-DG	Ø90x300/330	2.46
I251300	SPB-DG	Ø110x300/330	3.20
I285230	SPB-DG	Ø125x330/340	
I256300	SPB-DG	Ø160x300/330	4.65



Accessories:

InnoGain SPB-DG SV (Screwfeet)

Article	Description	Size (mm)	Weight (KG)
I295000	SPB-DG SV	Ø60,Ø70,Ø90,Ø110	0.30
I295160	SPB-DG SV	Ø160	0,74

InnoGain SPB-DG MV (Magnetfeet)

Article	Description	Size (mm)	Weight (KG)
I296000	SPB-D MV	Ø60,Ø70,Ø90,Ø110	0,80
I296160	SPB-D MV	Ø160	0,74



InnoWax

Article	Description	Size	Weight (KG)
I098025	InnoWax	1 ltr	0,90
I098030	InnoWax	5 ltr	4,50



Ballykillduff, Tobinstown, Tullow, Co. Carlow.

www.InnoGain.com

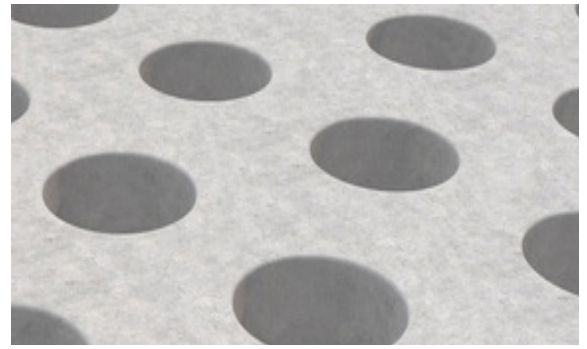

InnoGain SPB-DG

Installation guide:

- 1** A. For wooden moulds, the base SPB-DG SV should be screwed to the formwork or attached through the mould with a fixing bolt.
B. For steel moulds, the magnetic base SPB-DG MV should be placed on the formwork and can also be secured with a fixing bolt if required.

Place the InnoGain SPB-DG over the base SPB-DG SV or the SPB-DG MV.

- 2** Hand tighten the InnoGain SPB-DG until the screw achieves a positive stop.

- 3** The concrete fill level is a maximum of 50mm from the top of the InnoGain SPB-DG.

- 4** When the concrete is cured, undo the screw until the InnoGain SPB-DG is released from the base plate and pull straight out of the concrete. The InnoGain SPB-DG requires no cleaning and is usable immediately.

- 5** The result is a clean, dust free, profiled InnoGain hole.

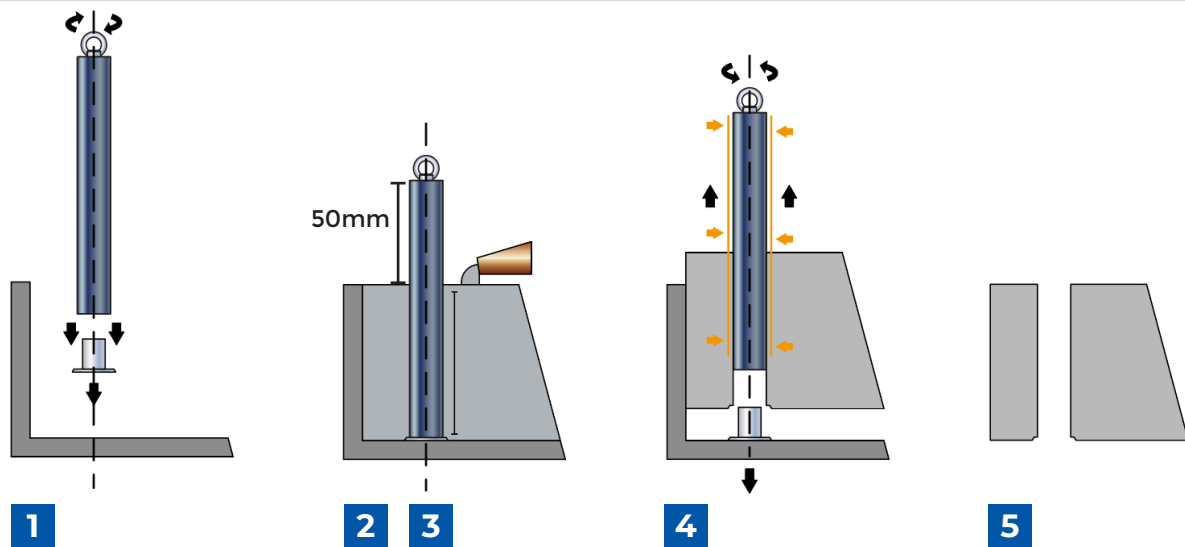

Important remarks:

- a. Care should be taken to avoid sharp edges which may damage the flexible outer cover.
- b. InnoGain should only be used in concrete.
- c. Always ensure the InnoGain is pulled squarely from the concrete.
- d. After protracted use the InnoGain can get dry noticed by increasing pull resistance – an application of InnoWax can be used to restore the InnoGain.
- e. Use InnoGain SPB-DG only for in vertical positions.

IMPORTANT: Directions for use are given for guidance only and are not intended to form part of any contract. They should be varied or adapted to suit your particular materials or conditions of use. Goods supplied by the company are made to approved standards from the highest quality raw materials but no warranty or guarantee is given as to their suitability for any particular purpose or application, and no liability is accepted for any loss or damage arising directly or indirectly from the use of the Company's products irrespective of any information given to us as to intended use of such products. It is therefore recommended that prospective users should test a sample of this product under their own conditions to satisfy themselves that the product is suitable for the purpose intended.

Instruction movie:

<https://innogain.nl/producten/spb-dg/>



Ballykillduff, Tobinstown, Tullow, Co. Carlow.

www.InnoGain.com